

REPLACEMENT PARTS

Supersedes: Nothing

e 530.18-RP6.63YI (796)

NOTE: FOR STYLE "B" MODELS SEE PAGE 7.

1 of 8

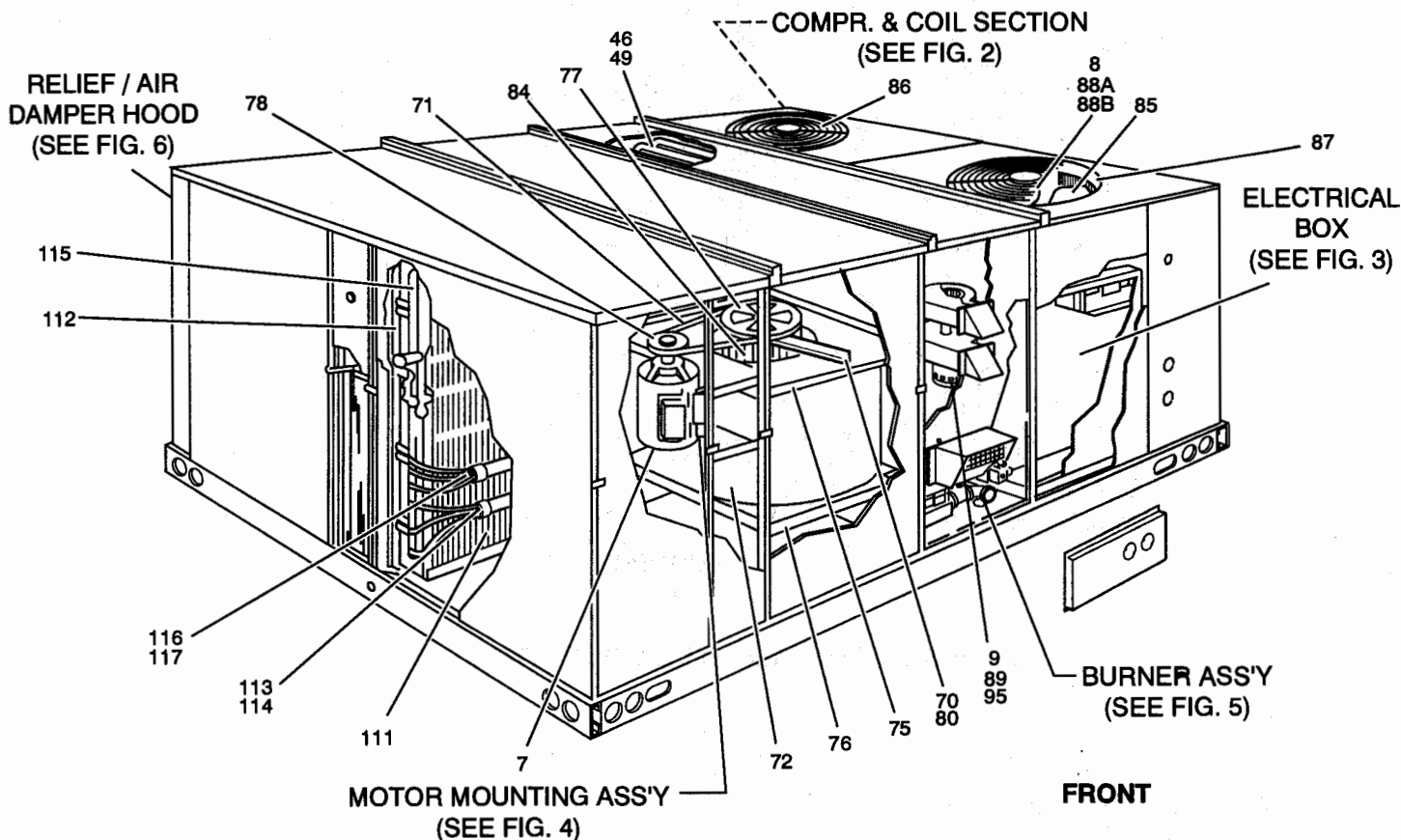

FIG. 1 - SINGLE PACKAGE GAS / ELECTRIC UNIT

COMPRESSOR

FIG	ITEM	DESCRIPTION	D3CG180N24050A (6-BURNER)
2	(1)	COMPRESSOR, HERMETIC (1-REQ'D)	015-02594-701
2	2	ISOLATOR, COMPRESSOR (4-REQ'D)	028-07772-000
2	3	SCREW, 5/16-18 HEX WASHER HD. W/SLEEVE	021-16803-000
2	(4)	COMPRESSOR, DUAL HERMETIC (1-REQ'D)	015-02543-705
2	5	ISOLATOR, COMPRESSOR DUAL (6-REQ'D)	028-12342-700
2	6	SCREW, 5/16-18 HEX WASHER HD. W/SLEEVE	021-16047-700

MOTORS

1	(7)	MOTOR, BLOWER (5HP)	024-24123-005
1	(8)	MOTOR, FAN (2-REQ'D)	024-25809-700
1	(9)	MOTOR, VENTOR (1-REQ'D)	024-25005-702

ELECTRICAL

3	10	BOARD, CIRCUIT RELAY	031-00652-700
*	11	BOOT, RUBBER CAPACITOR	028-04133-000
3	12	CIRCUIT BREAKER [CB]	024-24055-000
*	13	CONNECTOR, CAP (6-CIRCUIT) [S9]	025-20963-000
*	14	CONNECTOR, PLUG (6-CIRCUIT) [P9]	025-19670-000
*	15	CONNECTOR, PLUG (9-CIRCUIT) [P7]	025-21192-000

* NOT SHOWN

Major components and suggested stocking items are shown with item number in parenthesis "()".

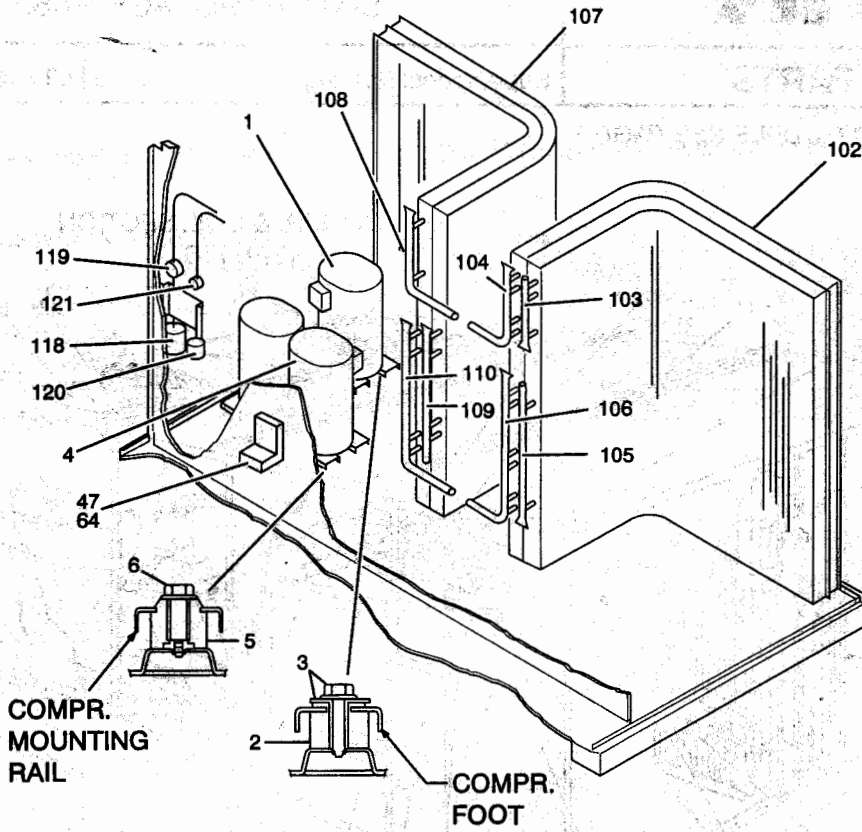

FIG. 2 - COMPRESSOR & COIL SECTION

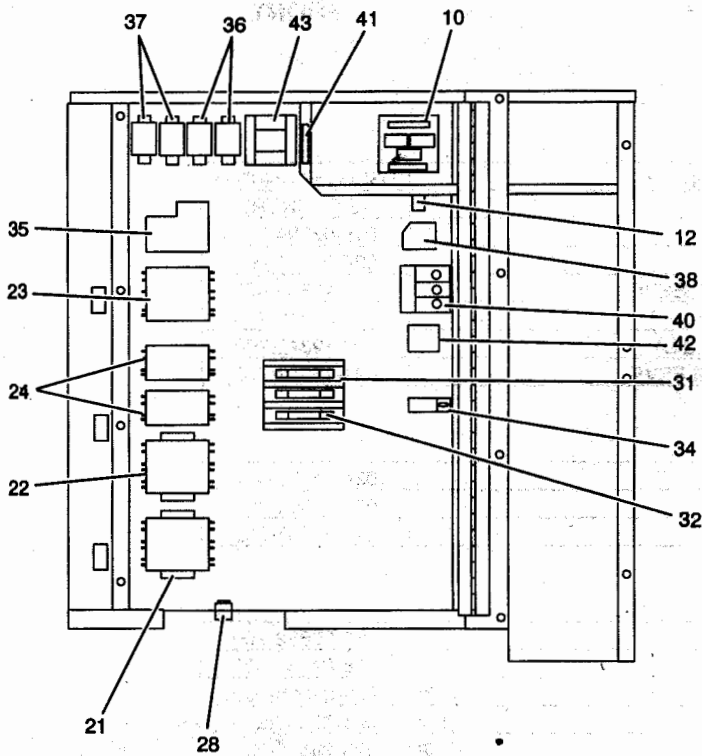
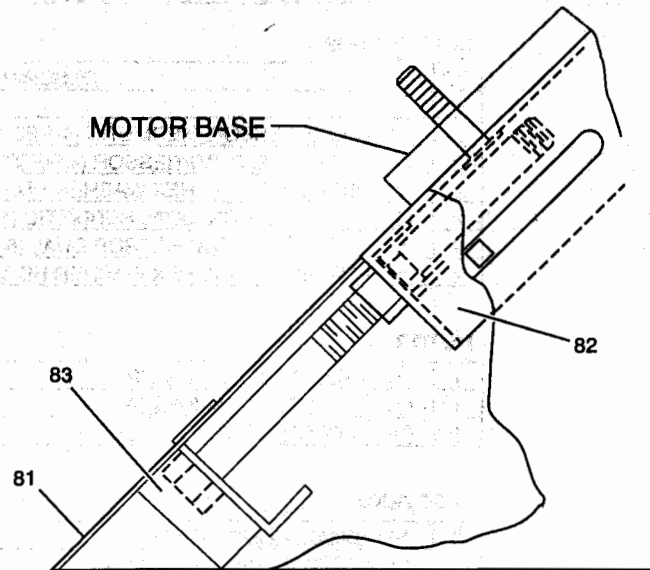

FIG. 3 - ELECTRICAL BOX



MOTOR MOUNTING / BELT TENSIONING ASSEMBLY
FIG. 4

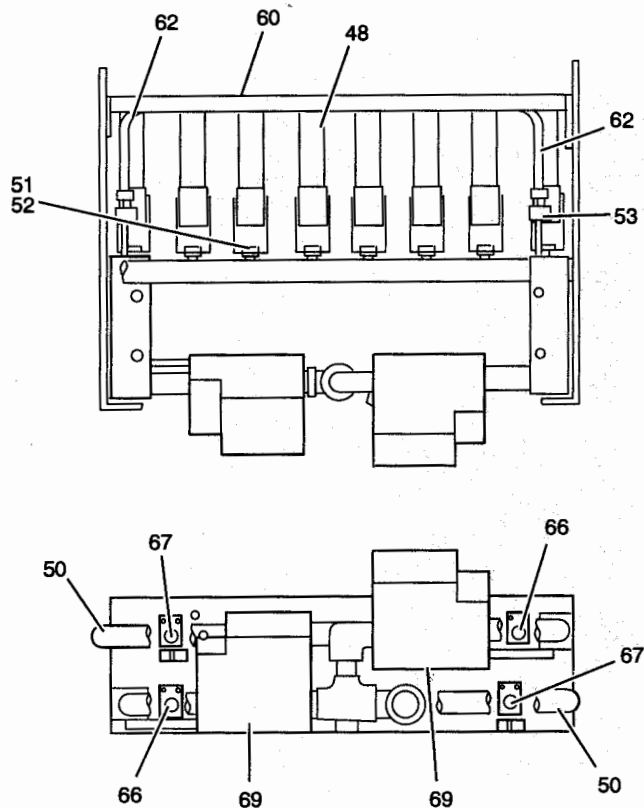

FIG. 5 - BURNER ASSEMBLY

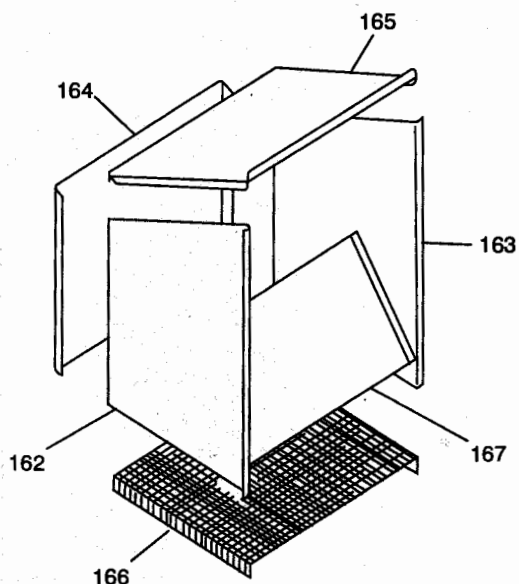

FIG. 6 - DAMPER HOOD (161)

ELECTRICAL (Cont.)

FIG	ITEM	DESCRIPTION	D3CG180N24050A (6-BURNER)
	16	SPACE FOR FUTURE PART ADDITIONS	
	17	SPACE FOR FUTURE PART ADDITIONS	
	18	SPACE FOR FUTURE PART ADDITIONS	
*	19	CONTACT, SOCKET (BOX OF 50) (1)	[P7] 025-19673-000
*	20	CONTACT, SPLIT PIN (BOX OF 50) (1)	[P6] 025-20919-700
3	(21)	CONTACTOR, ELEC.	[1M] 024-25842-700
3	(22)	CONTACTOR, ELEC.	[2M] 024-25842-700
3	(23)	CONTACTOR, ELEC.	[3M] 024-25842-700
3	(24)	CONTACTOR, ELEC.	[4M,5M] 024-25838-700
*	(25)	CONTROL, PRESSURE (2-REQ'D)	[HP1&2] 025-17620-725
*	(26)	CONTROL, PRESSURE (2-REQ'D)	[LP1&2] 025-30249-700
*	(27)	CONTROL, LOW EVAP. TEMP. (2)	[FS1&2] 025-27727-002
3	28	CONTROL, TEMP.	[TLA] 025-27723-001
	29	SPACE FOR FUTURE PART ADDITIONS	
	30	SPACE FOR FUTURE PART ADDITIONS	
3	31	FUSEHOLDER, CRTG. 600V	025-18284-000
3	32	FUSE, DUAL 600V/12A (3-REQ'D)	[7-9FU] 025-06079-000
*	33	LABEL, WIRING (REFERENCE)	035-12597-000
3	34	LUG, GROUND	025-19282-000
3	(35)	RELAY, BLOWER OVERLOAD	[BOR] 024-24127-001
3	(36)	RELAY, CONTROL	[RY1,2] 024-21678-000
3	(37)	RELAY, CONTROL	[RW1,2] 024-19138-001
3	(38)	RELAY, HEAT SEQUENCE	[TDR] 024-19082-038
	39	SPACE FOR FUTURE PART ADDITIONS	

* NOT SHOWN

- (1) USE HAND TOOL #044-02999-700 WHEN APPLYING CONTACT.
- (2) USE HEAT CONDUCTIVE COMPOUND 013-02250-000 WHEN APPLYING CONTROL TO SUCTION LINE.

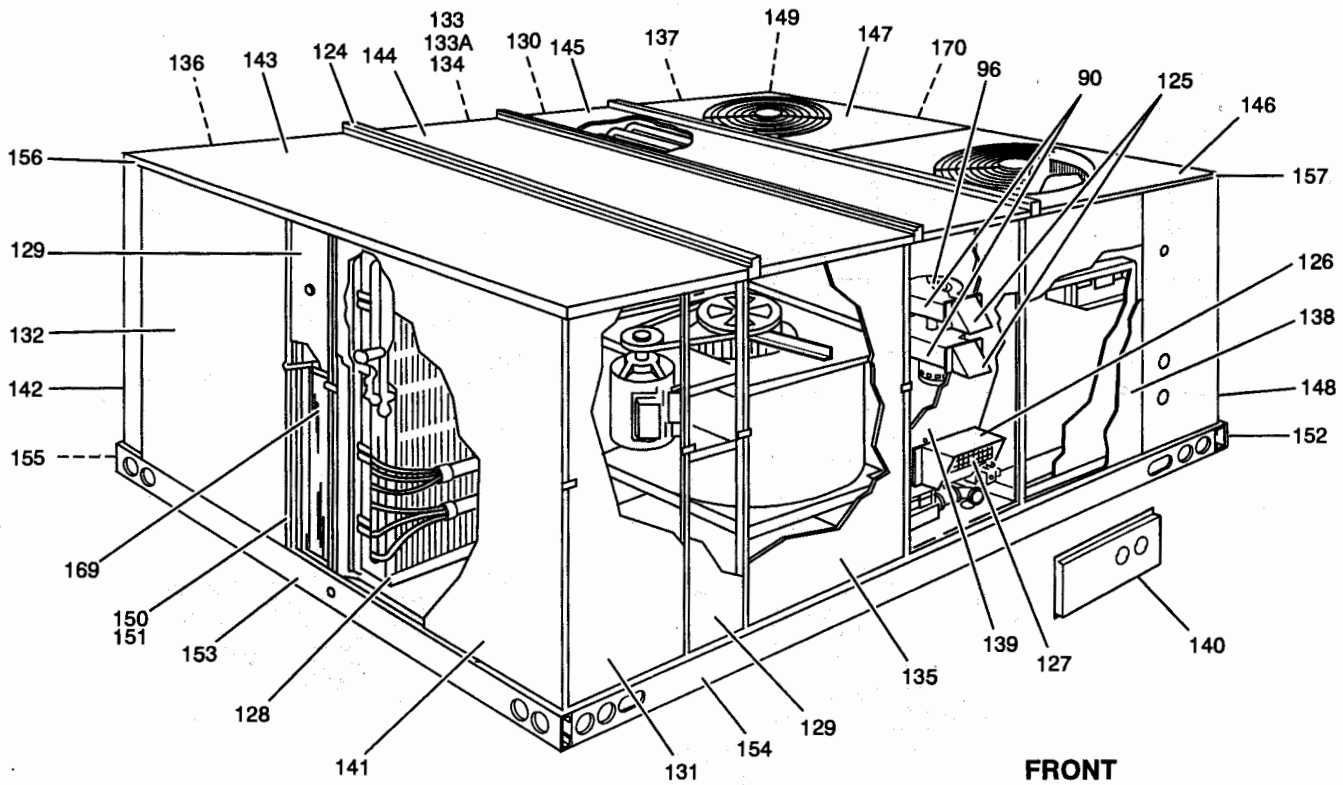

FIG. 7 - SINGLE PACKAGE GAS / ELECTRIC UNIT

ELECTRICAL (Cont.)

FIG	ITEM	DESCRIPTION	D3CG180N24050A (6-BURNER)
3	40	TERMINAL BLOCK 3-POLE [2TB]	025-20710-000
3	41	TERMINAL BLOCK 3-POLE [4TB]	025-27755-000
3	42	TERMINAL BLOCK 1-POLE [5TB]	025-30727-000
3	(43)	TRANSFORMER [1T]	025-30728-700
44		SPACE FOR FUTURE PART ADDITIONS	
45		SPACE FOR FUTURE PART ADDITIONS	

GAS HEAT SECTION

1	46	BAFFLE, AIR (HEAT EXCH. TUBE) 1-PER TUBE	063-90071-000
2	47	BRACKET, LIMIT SWITCH	063-94987-700
5	48	BURNER, GAS (6-REQ'D)	029-18431-000
1	49	HEAT EXCHANGER	363-93846-003
5	50	MANIFOLD, GAS (2-REQ'D)	029-20081-000
5	51	ORIFICE, GAS BURNER #30 (6-REQ'D)	029-20423-030
5	52	ORIFICE, GAS BURNER BLANK (2-REQ'D)	029-20423-000
5	53	ORIFICE, GAS PILOT #65 (2-REQ'D)	029-20422-065
*	54	PANEL, FRONT FLUE BOX	063-93865-700
*	55	PANEL, TOP FLUE BOX	063-93867-700
*	56	PANEL, MIDDLE FLUE BOX	063-93866-700
*	57	PANEL, BOTTOM & SIDES FLUE BOX	063-93849-000
*	58	PANEL, VESTIBULE (FRONT)	363-94871-020
*	59	PANEL, VESTIBULE (BOTTOM)	363-94871-100
*	60	SUPPORT, BURNER	063-93848-000
61		SPACE FOR FUTURE PART ADDITIONS	
5	62	TUBE, CARRYOVER (2-REQ'D)	029-20404-000

* NOT SHOWN

GAS/ELECTRIC CONTROLS

FIG	ITEM	DESCRIPTION	D3CG180N24050A
			(6-BURNER)
*	(63)	CONTROL, IGNITION [IC1&2]	025-29012-000
2	64	CONTROL, TEMP. (LIMIT) [LS]	025-26366-004
*	65	CONTROL, TEMP. (ROLLOUT)	025-27733-002
5	(66)	IGNITOR, SPARK (W/O TERM) (2-REQ'D)	025-27731-702
5	(67)	SENSOR, FLAME (W/TERM) (2-REQ'D)	025-27731-701
	68	SPACE FOR FUTURE PART ADDITIONS	
5	(69)	VALVE, GAS (HONEYWELL) (2-REQ'D)	025-27720-700

AIR MOVING (BLOWER)

1	70	BEARING, BALL PILLOW BLOCK (2-REQ'D)	029-20424-700
1	71	BELT, FAN (BX-68)	028-10382-000
1	72	HOUSING, BLOWER 15" W/O WHEEL	073-01951-000
*	73	KEY, STEEL 1/4 SQ. X 2" LG. (FIXED PULLEY)	001-07110-005
*	74	KEY, STEEL 1/4 SQ. X 6-3/8" LG. (WHEEL)	001-07110-004
1	75	PLATE, TOP 15" BLOWER	063-89998-000
1	76	PLATE, BTM. 15" BLOWER	063-89999-000
1	77	PULLEY, FIXED PITCH (BLOWER)	028-10564-000
1	78	PULLEY, VARIABLE PITCH (MOTOR)	028-04761-700
*	79	SHAFT, BLOWER	001-07117-000
1	80	SUPPORT, BEARING (2-REQ'D)	063-89950-000
4	81	SUPPORT, MOTOR MOUNTING	063-94674-000
4	82	PLATE, MOTOR MOUNTING W/4-WELD SCREWS	373-01956-000
4	83	BRACKET, TENSIONER (MOTOR SUPPORT)	063-94940-000
1	84	WHEEL, BLOWER 15"	026-25529-704

AIR MOVING (COND. FAN)

1	(85)	BLADE, FAN (2-REQ'D)	026-32577-700
1	86	GUARD, FAN (2-REQ'D)	026-25549-000
1	87	ORIFICE, FAN (2-REQ'D)	063-94820-000
1	88A	MOUNT, FAN MOTOR (WIREFORM) (2-REQ'D)	026-25551-000
1	88B	CLAMP RING FOR MOTOR MOUNT (2-REQ'D)	026-25568-000

AIR MOVING (VENTOR)

1	89	VARISTOR (VENTOR MOTOR PROTECTOR)	025-30145-000
7	90	HOUSING, VENTOR BLOWER (2-REQ'D)	063-90041-000
*	91	PLATE, VENTOR ORIFICE (TOP HSG.)	063-90038-020
*	92	PLATE, VENTOR ORIFICE (BOTTOM HSG.)	063-90038-021
*	93	PLATE, VENTOR (TOP HSG.)	073-03170-000
*	94	PLATE, VENTOR (BOTTOM HSG.)	073-03210-000
1	95	SPACER, VENTOR MOTOR (4-REQ'D)	073-03169-000
7	96	WHEEL, VENTOR BLOWER (UPPER)	026-32626-700
*	97	WHEEL, VENTOR BLOWER (LOWER)	026-32625-700
	98	SPACE FOR FUTURE PART ADDITIONS	

REFRIGERANT

*	99	CAP. SEAL 1/4 FLARE	023-11018-000
*	100	CORE, VALVE	022-02475-000
*	101	STEM, VALVE (1/4 OD TUBE)	022-08017-000
2	102	COIL, CONDENSER (FRONT FORMED) (3)	373-10890-700
2	103	HEADER, COND. (FRONT COIL / TOP FRONT)	373-10890-750
2	104	HEADER, COND. (FRONT COIL / TOP REAR)	373-10890-760
2	105	HEADER, COND. (FRONT COIL / BTM. FRONT)	373-10890-770
2	106	HEADER, COND. (FRONT COIL / BTM. REAR)	373-10890-780

* NOT SHOWN

(3) INCLUDES HEADERS.

REFRIGERANT (Cont.)

FIG	ITEM	DESCRIPTION	D3CG180N24050A (6-BURNER)
2	107	COIL, CONDENSER (REAR FORMED) (3)	373-10885-700
2	108	HEADER, COND. (REAR COIL / TOP)	373-10885-750
2	109	HEADER, COND. (REAR COIL / BTM. FRONT)	373-10885-760
2	110	HEADER, COND. (REAR COIL / BTM. REAR)	373-10885-770
11	111	COIL, EVAPORATOR (SYS. 1 & 2) (4)	373-06227-000
1	112	HEADER, EVAP. (SYS. 1)	373-06227-730
1	113	VALVE, TXV (INLET 1/2, OUTLET 7/8) (SYS. 1)	022-06852-001
1	114	VALVE, DISTR. ASS'Y. (INCL. 8 TUBES) (SYS. 1)	026-32679-701
1	115	HEADER, EVAP. (SYS. 2)	373-06227-720
1	116	VALVE, TXV (INLET 3/8, OUTLET 5/8) (SYS. 2)	022-06848-010
1	117	VALVE, DISTR. ASS'Y. (INCL. 4 TUBES) (SYS. 2)	026-32679-702
2	118	FILTER, DRIER (1/2 CONN.)	026-14777-712
2	119	INDICATOR, MOISTURE LIQUID (1/2 CONN.)	026-12525-700
2	120	FILTER, DRIER (3/8 CONN.)	026-14777-706
2	121	INDICATOR, MOISTURE LIQUID (3/8 CONN.)	026-25561-000
	122	SPACE FOR FUTURE PART ADDITIONS	
	123	SPACE FOR FUTURE PART ADDITIONS	

FABRICATED PARTS

7	124	CAP, ROOF (3-REQ'D)	063-94959-700
7	125	HOOD, FLUE OUTLET W/SCREEN (2-REQ'D)	363-93686-700
7	126	HOOD, AIR INLET W / O SCREEN	063-94817-000
7	127	SCREEN, AIR INLET	026-31407-000
7	128	PAN, DRAIN	373-05199-701
7	129	PANEL, ACCESS FILTER & MOTOR (2-REQ'D)	373-06208-180
7	130	PANEL, ACCESS HEAT SECT. (REAR)	363-06208-190
7	131	PANEL, ACCESS (LEFT FRONT)	373-06208-170
7	132	PANEL, ACCESS FRESH AIR (EVAP. END)	373-06208-210
7	133	PANEL, ACCESS (DAMPER MTG.) W/O ECONO.	363-94829-030
7	133A	COVER, DAMPER OPENING	363-94829-032
7	134	PANEL, ACCESS (ECONO. MTG.) W/ECONO.	373-06208-210
7	135	PANEL, ACCESS (BLOWER)	373-06208-280
7	136	PANEL, ACCESS (DAMPER)	373-06208-220
7	137	PANEL, ACCESS (COMPRESSOR)	073-01923-000
7	138	PANEL, ACCESS (CONTROLS)	073-01922-000
7	139	PANEL, ACCESS (HEAT SECT. FRONT, UPPER)	073-01983-000
7	140	PANEL, ACCESS (HEAT SECT. FRONT, LOWER)	063-94769-000
7	141	PANEL, CORNER (EVAP. SIDE FRONT)	373-06208-230
7	142	PANEL, CORNER (REAR L/H)	373-06208-200
7	143	PANEL, TOP (EVAP. L/H)	373-06208-140
7	144	PANEL, TOP (EVAP. R/H)	373-06317-150
7	145	PANEL, TOP (HEAT SECTION)	373-06317-160
7	146	PANEL, TOP (CONDENSER FRONT)	063-93750-000
7	147	PANEL, TOP (CONDENSER REAR)	063-93751-000
7	148	POST, CORNER (R/H FRONT)	073-02034-000
7	149	POST, CORNER (R/H REAR)	073-02033-000
7	150	POST, FRAME (INNER) (8-REQ'D)	073-01987-700
7	151	POST, FRAME (OUTER) (8-REQ'D)	073-01986-700
7	152	RAIL, BASE (COND. END)	073-10757-700
7	153	RAIL, BASE (EVAP. END)	073-10807-700
7	154	RAIL, BASE (FRONT)	073-01937-700
7	155	RAIL, BASE (REAR)	073-01938-700
7	156	RAIL, TOP (EVAP. END)	063-94943-700
7	157	RAIL, TOP (FRONT & REAR) (2-REQ'D)	073-01981-700
	158	SPACE FOR FUTURE PART ADDITIONS	
	159	SPACE FOR FUTURE PART ADDITIONS	
	160	SPACE FOR FUTURE PART ADDITIONS	

* NOT SHOWN

(3) INCLUDES HEADERS.

(4) INCLUDES HEADERS, TXV'S, DISTRIBUTOR VALVES & TUBES.

DAMPER HOOD

FIG	ITEM	DESCRIPTION	D3CG180N24050A
			(6-BURNER)
6	161	HOOD, DAMPER ASS'Y COMPLETE	373-02274-701
6	162	PANEL, DAMPER (RIGHT SIDE)	073-02266-700
6	163	PANEL, DAMPER (LEFT SIDE)	073-02267-700
6	164	PANEL, DAMPER (FRONT)	073-02268-700
6	165	PANEL, DAMPER (TOP)	073-02269-700
6	166	SCREEN, DAMPER (BLANK)	026-31409-700
6	167	BAFFLE, DAMPER	073-02272-700

MISC.

*	168	CATCH, MAGNETIC (2-REQ'D)	029-15650-000
7	169	FILTER, AIR (5-REQ'D)	(2x18x24)
7	170	GUARD, COIL (2-REQ'D)	026-31432-701
*	171	GROMMET, PVC RED (2.375 HOLE)	028-04698-000
*	172	ELBOW, 90 DEG.	023-01643-000

* NOT SHOWN

NOTE: **STYLE "B" MODELS ARE THE SAME AS STYLE "A" EXCEPT FOR THE FOLLOWING PARTS:**

FIG	ITEM	DESCRIPTION	D3CG180N24050B
1	(9)	MOTOR, VENTOR	024-25005-004
*	33	LABEL, WIRING (REFERENCE)	035-13840-000
3	(38)	RELAY, HEAT SEQUENCE [TDR]	024-19082-740
2	64	CONTROL, TEMPERATURE (LIMIT) [LS]	025-26366-009
*	63	CONTROL, IGNITION [IC1 & 2]	025-29012-001
1	89	VARISTOR	OMIT
*	11	BOOT, RUBBER CAPACITOR	OMIT
7	126	HOOD, AIR INLET W/O SCREEN	073-16451-000
7	127	SCREEN, AIR INLET	026-34563-000
7	137	PANEL, ACCESS (COMPRESSOR)	073-01923-001
7	138	PANEL, ACCESS (CONTROLS)	073-01922-001
7	139	PANEL, ACCESS (HEAT SECT. FRONT, UPPER)	073-16452-003

New replacement parts shown in **bold face** type at the first printing of Parts List code dated 7/96.

FOR FACTORY OR FIELD INSTALLED ACCESSORIES SEE THE FOLLOWING PARTS LIST:

ACCESSORIES - ELECTRICAL

DESCRIPTION	MODEL NO.	USED WITH
LOW AMBIENT TO 0 DEG. F	2LA04703546	ALL MODELS
ANTI-RECYCLE TIMER	2AC04700424	ALL MODELS
ELECT. ENTHALPY ECONO. / SINGLE INPUT	2EE04701824	ALL MODELS
ELECT. ENTHALPY ECONO. / DUAL INPUT	2EE04701324	ALL MODELS
MOTORIZED OUTDOOR AIR DAMPER	2MD04702125	NO ECONO.

ACCESSORIES - NON-ELECTRICAL

DESCRIPTION	MODEL NO.	USED WITH
PROPANE CONVERSION KIT	1NP0418	ALL MODELS
HIGH ALTITUDE - NATURAL GAS	1HA0409	ALL MODELS
HIGH ALTITUDE - PROPANE	1HA0408	ALL MODELS
BAROMETRIC RELIEF DAMPER	1RD0405	UNIT W/ECONO.
HIGH SPEED DRIVE	1LD0416	ALL MODELS



Heating and Air Conditioning

